

Paper Production - Calender Barring

Problem: Self-excited vibration and related regenerative wear in paper machine calender stacks reduce paper quality and increase maintenance costs.

The final finishing operation in most paper machines is the calendering operation. The paper sheet passes between a series of four to eight vertically stacked rolls called the calender stack. The paper is compressed or calendered as it passes between the rolls, obtaining the desired thickness and gloss characteristics. Self excited vibration of the calender stack and regenerative wear of the calender rolls is a chronic problem experienced by many paper mills. These phenomena are collectively known as calender barring. Variation in paper thickness and gloss and premature wear of calender rolls are costly symptoms of calender barring. While much work has been done to understand calender barring it re-

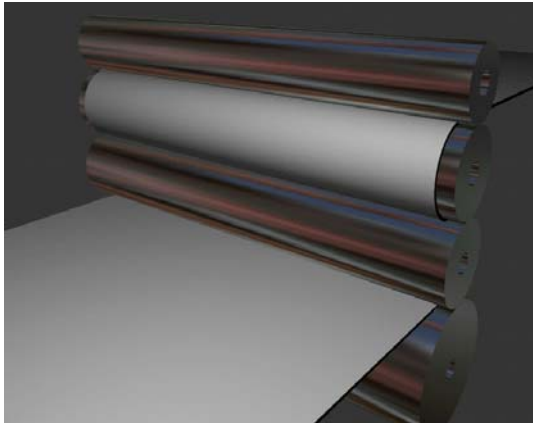

Solid Model of Paper Sheet Feeding Through Four-Roll Roll Calender Stack

mains a baffling and costly problem. SDL worked with Abitibi-Price, Inc., and LSZ Paper Tech, Inc., to develop a meaningful computer model of calender barring which incorporates both the paper sheet feedback and regenerative wear mechanisms and the interaction between them. The model is based on vibration testing of an operating calender stack, recent PAPRICAN research on paper properties and SDL's exper-

Solution: Experimental testing of an operating calender stack and analytical modeling was conducted to develop a meaningful computer model of the calender barring process. The model guides choice of calender stack setup and machine operating parameters to avoid barring.

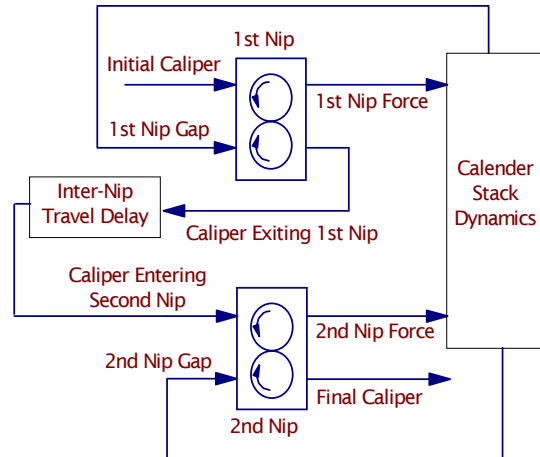

Block Diagram of Computer Model of Three-Roll Calender Stack

tise in self-excited dynamic systems. The computer model can be tuned to specific paper machines and used to guide selection of calender stack setup parameters and paper machine operating conditions to avoid barring. An on-line barring monitor was also developed which measures whether the machine is operating in a stable or unstable barring mode.

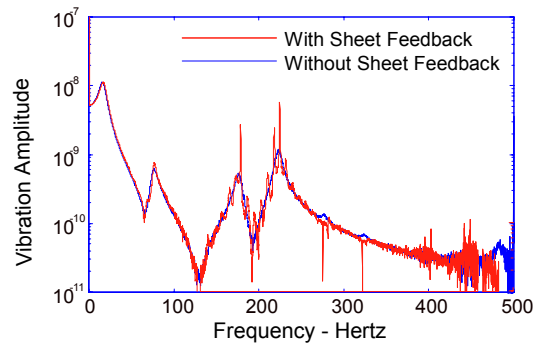

Computer Prediction of Calender Stack Response With and Without Paper Feedback

SDL

■ Embedding Intelligence in your Products and Processes ■

Contact us at:
Phone: 513-631-0579
Fax: 513-631-0582
info@sdlltd.com
www.sdlltd.com